

HZ-109S Primary Current Injection Test Set



Contents

Safety Precautions.....	1
I. Overview.....	2
II. The Main Performance Index.....	2
III. Instruction Of Panel And Function.....	3
IV. Principle Of Operation.....	4
V. Usage.....	4
VI. Packing List.....	6

Safety Precautions

1. In order to ensure the safe operation of test, the instrument should be grounded reliably before the test.

2. The power supply voltage should be set as $220V\pm 10\%$. Do not input 380V power supply into the instrument, or the instrument will be severely damaged.

3. Connecting or disconnecting the test wire is strictly prohibited when the test is conducting.

4. For the test set, the cable cross-section of input power should be greater than 2mm^2 , and the cable cross-section of high current output connection should be greater than 70mm^2 , and the cable length of the output connection should be kept as short as possible.

5. Use paralleling output wherever possible, if only the demand of output current is met.

6. Avoid continuous output in a long time.

I. Overview

Adopted technology of ARM chip controlling output and toroidal transformer with high-capacity and equipped with LCD display meter, the HZ-109S Primary Current Injection Tester could simultaneously display primary current, secondary current, turn ratio and the actuation time of stopwatch connection position (electric potential). The product possesses the characteristics of nice appearance, large output capacity, small size, light weight and so on with external aluminum alloy case and PC panel. It is mainly suited for CT turn ratio and contact resistance tests of power system and other occasions needed high current test.

II. The Main Performance Index

2.1 Input Power Supply: AC: 220V·25A,50Hz.

2.2 Output Current: AC: 1000A·5V or 500A·10V.

2.3 LCD Screen Digital Display: Simultaneous display of primary current and secondary current as well as the turn ratio;

The Range of Primary Current: 0~1100A, Resolution: 0.1A;

The Range of Secondary Current: 0~6A; Resolution: 0.001A.

Stopwatch: 0.0001~999.99S precision ± 5 significant figures.

2.4 Precision: TRUE RMS $\pm 0.5\%$.

2.5 Duplicate Protection (electronic overload protection and software protection).

2.6 Usage Environment: Temperature -10~40°C,

Relative humidity <80%.

2.7 Volume; 430×260×260mm³.

2.8 Weight: 28kg.

III. Instruction Of Panel And Function



- 3.1 Ground Terminal: to ensure safe operation, please ground the wiring terminal.
- 3.2 The Terminal of Power Supply Input: AC: 220V power supply is imported from the two terminals colored in red and black.
- 3.3 Indicated lights of Power supply: when the power inputs, the indicated light is on, if not, it notes that the incoming line has no power input and please check the incoming power line.
- 3.4 The Terminal of high current output.
- 3.5 Series or parallel pressure plate.
- 3.6 Series or Parallel Button: it presents series connection when the second pressure plate are put in the middle (that is the button is pressed).
- 3.7 The input terminal of secondary current measurement. .
- 3.8 The input terminal of stopwatch, and the stopwatch electric potential or the switch of connection points.
- 3.9 LCD (Liquid Crystal Display) which displays the value of primary current and secondary current, the turn ratio and the stopwatch.
- 3.10 Contrast control of LCD.
- 3.11 Serial port, which could be connected with PC externally for program updates.
- 3.12 Output/ Cut off button (the red light is on when output).
- 3.13 Adjusting knob of high current output.

3.14 Power Switch: that is fast protection switch which is used for input power control and overload protection (of the instrument).

IV. Principle Of Operation

The circuit is shown as the following figure. Input from X5~X6, AC: 220V power flows through the main switch KG, adjusted by voltage regulator TY, controlled by K1 and risen by amplifier, and then outputs large current via current transformer from X1~X4. The two paralleling coils will output 1000A current, meanwhile, the maximum no-load voltage is 5V; the two series coils will output 500A current, meanwhile, the maximum no-load voltage is 10V.

ARM controller deals with data display of mouse and signal panel, the output of stopwatch (connection positions or electric potential) and control.

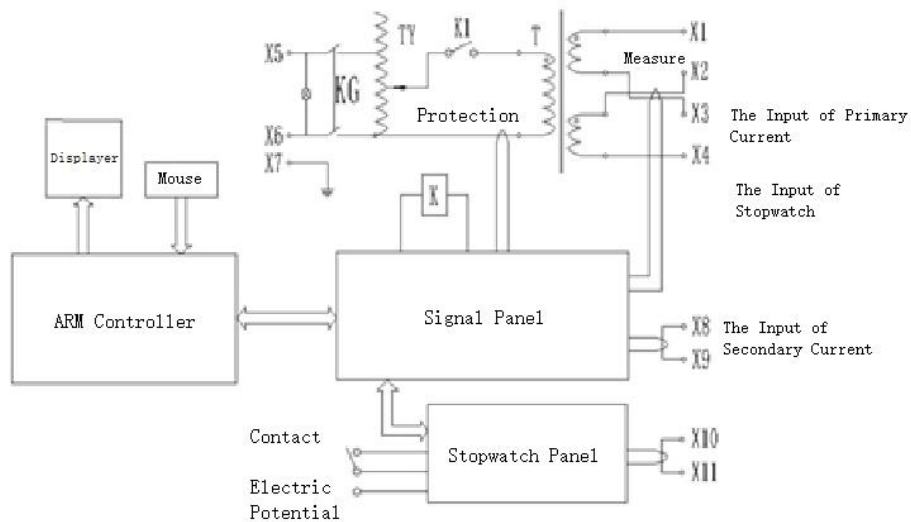

V. Usage

After the connection with our company special-purpose wires, such as special power input wire, special output high current wire, secondary circuit wire, stopwatch connecting position wire and ground wire, firstly make the voltage regulator back to zero, then plug in 220V power (if the on-site power sockets are installed far away, it is necessary to use power supply plate and the cross-section of wires should be at least

4.0mm², or the output power will be affected.) and then turn on the main switch, and finally it will enter into the user interface with *Welcome to use Primary Current Injection Tester HZ-109S* shown on the screen. As illustrated in following figure, at this point press rotating mouse and the *startup* will turn into a *stop*. Then adjust the knob of voltage regulator, the current will flow from high current terminal and an output primary current value will be displayed on the primary ammeter. At that time if secondary current input wire is in connection states, the secondary ammeter will display corresponding value and the turn ratio (0.000/5) of tested instrument transformer. After actuation of stopwatch connection, the actuation value will be shown. When *open* changes into *close* if press rotating mouse, *stop* will turn into *start* and the output ends. Rotate rotating mouse and select 5 of turn ratio by cursor and press, then 5 will change into 0.001/1. After output in that time, showing the turn ratio of instrument transformer.

Double-circuit: inside clock, connection position and potential stopwatch

Single-circuit: outside clock or outside stopwatch select double-circuit by using cursor and press the button to turn into single-circuit

Reset: select this text by using cursor and press the button to reset stopwatch.

Turn Ratio:		0.000/5
I1 : 0.0A	I2: 0.000A	
Stopwatch : 0.0000S	Open	
Start	Reset	<i>Double-circuit</i>

The operation of stopwatch: default of the instrument is double-circuit, that is, inside clock and outside stopwatch of connection position (or electric potential); the connection position of stopwatch is located at NC (normally closed) or NO (normally open) of the circuit breaker (or operating point of electric potential. Note: the time located in action potential will be used when there is no connection position and meantime turn on the electric potential switch of the instrument). Firstly, adjust knob of

voltage regulator under the state of output to ensure the action of circuit breaker, then stop output and connect the wire of stopwatch and action connect position of circuit breaker (or action potential point), finally press the output button and the actuation time will be obtained. The method of wiring is shown as follows:

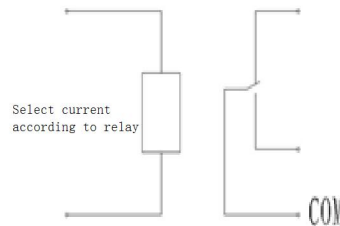

In single-circuit, connecting (potential) action is implemented, the clock will start and the connecting (or potential) action is implemented again, the clock will stop. The current of circuit breaker could be externally added.

VI. Packing List

No.	Item	Qty
1	Main engine	1
2	Test line	2
3	Power line	1
4	Double core sheathed wire	2
5	Ground lead	1
6	Small clip	5
7	Insert	1