

HZ-504

Cable Route Tracer

Manual



HZ-504 Cable Route Tracer

§1、 Introduction

Cable Route tracer is specially-designed for detecting the underground cable layout position and underground depth in a certain range.

Cable route detector consists of signal transmitter and receiver (Cable fault pinpoint detector), both of which finish the detection. By united operation the Cable route detector could exactly pinpoint the cable route in the probable range of cable burial.

§2 、 Main consist of cable route tracer

Cable route tracer mainly consists of route signal transmitter and receiver.

2.1 Cable Route signal transmitter

Cable route tracer is the big power route signal transmitter required in detecting the underground cable route.

2.1.1 Main Technical Index Parameters.

- a) big power output, anti-vibration, strong anti-interference ability, stable and reliable;
- b) With reliable over current, open circuit and short circuit protection function;
- c) Output Frequency: Audio Frequency.
- d) Output signal: intermittent, 0~50Vpp
- e) Working power supply: 220V (1±10%) 50Hz (1±5%);
- f) Output power: 100W;
- g) Output current: 0~2A;

2.1.2 Working principle.

Working principle diagram.

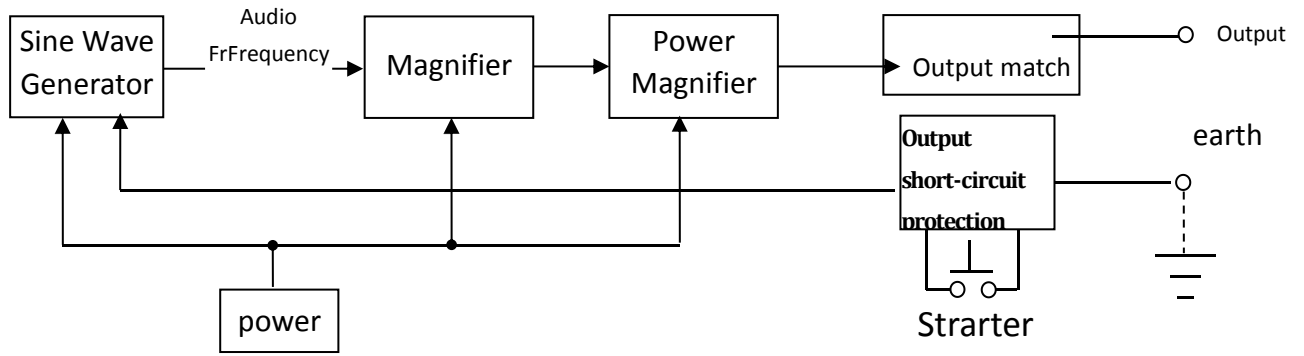

Cable Route tracer Working Principle Diagram

Sine Wave generator output audio sine wave signal, which load to Power magnifier by control circuit, The power output impedance matching “output”. If the output end load short-circuit (< 2 ohms), signal source will immediately protected, once the load short circuit condition exclusion, press the "start" button, signal source recovery normal work.

2.1.3 Cable route tracer (route signal generator) Panel layout

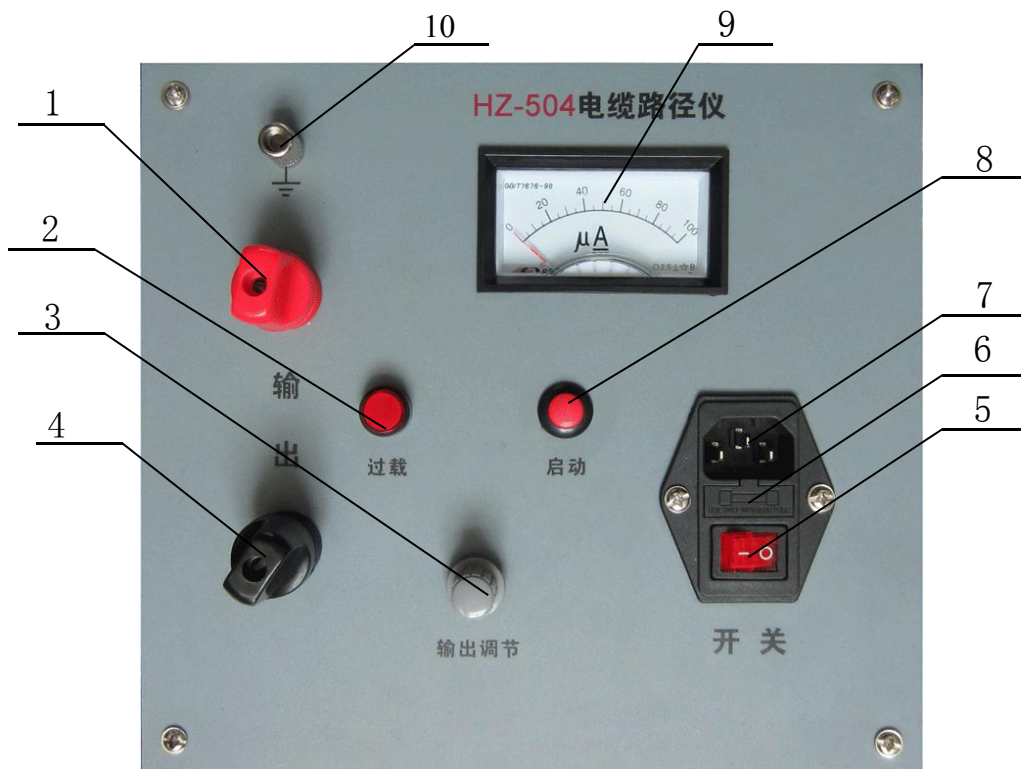

Cable route tracer panel diagram.

- 1、 Output Positive : Signal source output positive,connected to cable phase line.
- 2、 Overload indicator : Overload indicator light, the light is on at the condition of output short-circuit or too large signal.
- 3、 Output adjustment: output amplitude adjustment knob, it can change the size of the output amplitude;
- 4、 Output negative: signal output negative, connect to the ground wire;
- 5、 Power switch: turn on the power to make the path instrument work, and at the same time there is an indicator light;
- 6、 Fuser pipe : A2 Fuser pipe; one for spare.
- 7、 Power input: input 220V (1 + 10%) 50Hz (1 + 5%);
- 8、 Start button: when the overload lights, reduce the output amplitude, then the key can restart signal generator, the signal path to the output
- 9、 The output header: when the head pointer swing it show the output signal; when the pointer does not move without the output signal; the pointer swing amplitude of said output signal amplitude (trend of numerical output, larger or smaller does not represent a specific unit value);
- 10、 Grounding pillar: the test site to connect safely to the earth.

2.2 Cable route receiver (Cable fault pinpoint locator)

Receiving the signals from the cable route tracer, by this detect exactly the depth and trace of underground cable.(HZ-503 Introduction)

§3 Cable route tracer operation.

3.1 Usage.

3.1.1 Probe connection

- a) Connect the power supply line
- b) Connect the red pillar (output positive) to fault cable (or working cable) phase.“Earth”black pillar (output negative),the other terminal three phase of cable should be

open circuit to ground. If outputting signal is weak, Pls connect the other cable terminal is short circuit to earth.

Diagram

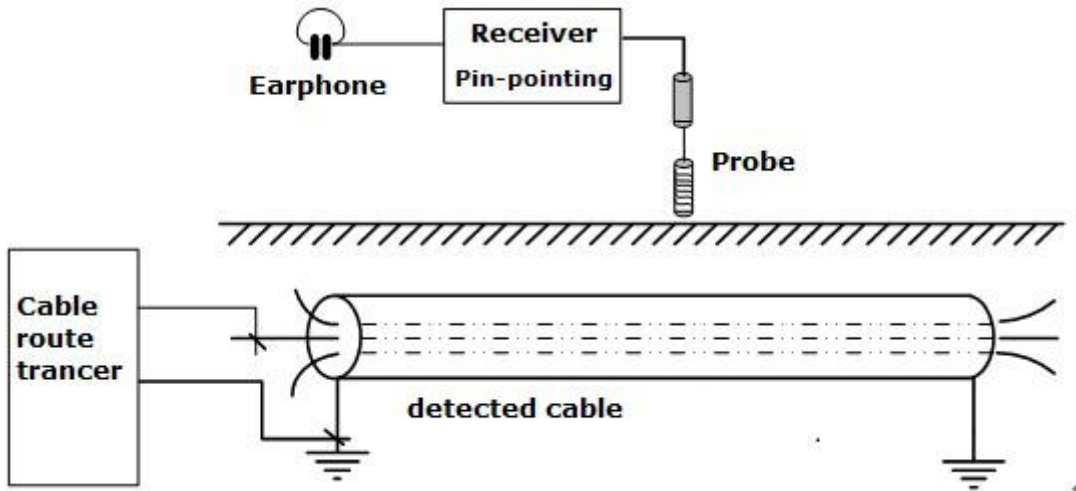

General route detect connecting wire diagram.

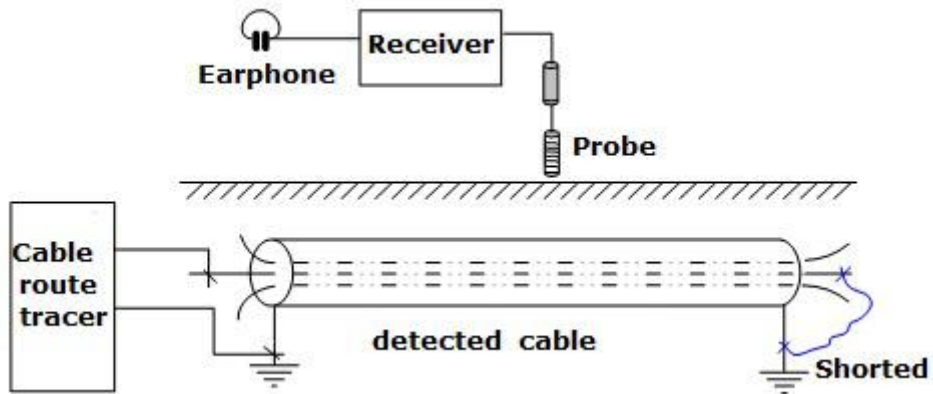

Super-length or breaking cable route detection wiring diagram.

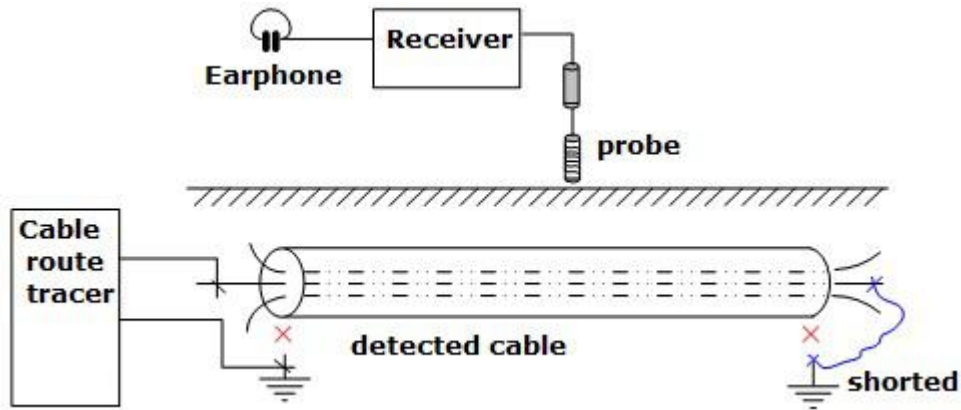

Special route detection wiring diagram.

3.1.2 Output signal initial adjustment.

Rotate "output adjustment knob" to minimum anti-clock wise.

3.1.3 Pre-adjustment after getting through the power supply.

Press the power switch, the power indicator light; adjust "adjustable output regulation" make "output header" in the appropriate range. If the measured cable length is more than a few kilometers away, can make the the pre-adjusted output voltage increase; if the "overload" light, reduce the output amplitude, press the "start" button to restart the signal.

3.2 a) the receiver probe and the headset operation

b) Receiver (Pinpoint locator) "working selection" switch to "route" position, at this time the receiver should receive the audio route signal. "Audio volume adjustment" put in appropriate position, adjust "frequency micro-adjustment" potentiometer, which make the headphone beat output the intermittent sound. The minimum points of the probe perpendicular to the ground hear into line, is buried buried cable path.

c) To assess the cable laying depth can be measured in cable position above, will probe into the ground 45 angle perpendicular to the path to move outward when the headset sound signal weakest, the buried depth is the translated probe distance of cable above.

Diagram 4

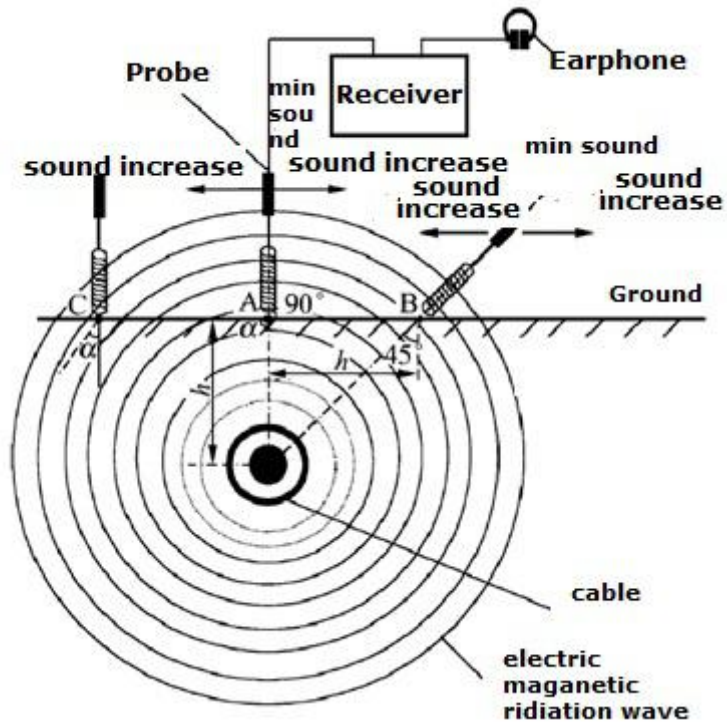

probe position diagram

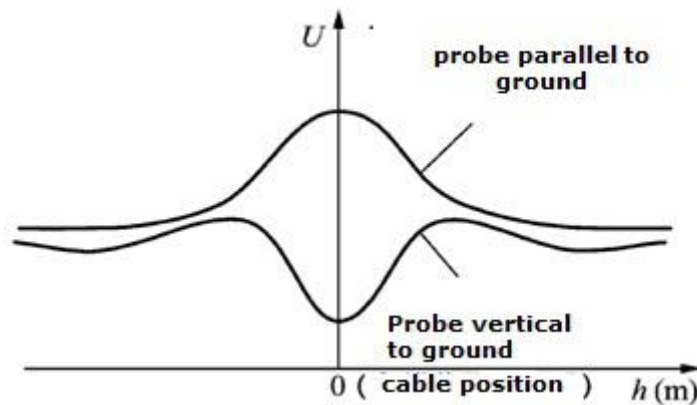

Route detection receiver amplitude and position diagram

Namely in detecting cable path to position, to always keep a vertical state of the probe and the horizontal plane, when the probe in the cable to position is above, received "headphones sound" is a relative minimum, namely "relative indication minimum location on the ground connection is the measuring cable route go to position.

Also in detecting cable path buried depth, should make a probe and cable to vertical and angle with the horizontal plane into 45; to the side of the moving probe, "headphones sound"

are a change from big to small, from small to big, that at the end of the "relative indication" minimum ground the cable ground to the vertical distance is the cable in the premises of the buried depth.

§4 Site detection notes

a) If the "output" overload signal or cable to be tested are short-circuit phenomenon, route instrument "overload" indicator light, signal source No output; at this time should reduce source output regulation or exclude the measured cable short circuit

(it is best to use "good phase") , then press the "start" button to get the normal work of the signal source

b) Before detection the operator should read the operation manual carefully so as to operate the instrument fluently; in the process of detection, the “adjustment knob “should keep stable, which can make the headphone sound “big” “small “stable and reliable. All of which could gurateen the detected results are exact. Therefore, the operation experience of the operator proficiency level and experience accumulation is one of the necessary preconditions for the successful detection of the cable path

c) Always do the detection marks, mark clear and credible, so as to avoid unnecessary rework the retest phenomenon.

d) When the power switch is turned on, the light does not shine ,Pls check the insurance tube.

e) In strict accordance with the electric power industry operating procedures, safe operation, to ensure personal safety and equipment in good condition, so that the detection test carried out smoothly.